

| MINIMUM TRENCH WIDTHS IN EARTH & MAXIMUM PAY WIDTHS FOR ROCK EXCAVATION | | | |
|---|----------------|---------------|---------------|
| PIPE DIA. | WIDTH IN EARTH | WIDTH IN ROCK | WIDTH IN ROCK |
| UP TO 4" | 2'-0" | 1'-0" | 1'-0" |
| 4" TO 6" | 2'-6" | 1'-6" | 1'-6" |
| 6" TO 8" | 3'-0" | 2'-0" | 2'-0" |
| 8" TO 10" | 3'-6" | 2'-6" | 2'-6" |
| 10" TO 12" | 4'-0" | 3'-0" | 3'-0" |
| 12" TO 14" | 4'-6" | 3'-6" | 3'-6" |
| 14" TO 16" | 5'-0" | 4'-0" | 4'-0" |
| 16" TO 18" | 5'-6" | 4'-6" | 4'-6" |
| 18" TO 20" | 6'-0" | 5'-0" | 5'-0" |
| 20" TO 24" | 6'-6" | 5'-6" | 5'-6" |
| 24" TO 30" | 7'-0" | 6'-0" | 6'-0" |
| 30" TO 36" | 7'-6" | 6'-6" | 6'-6" |
| 36" TO 42" | 8'-0" | 7'-0" | 7'-0" |
| 42" TO 48" | 8'-6" | 7'-6" | 7'-6" |
| 48" TO 54" | 9'-0" | 8'-0" | 8'-0" |
| 54" TO 60" | 9'-6" | 8'-6" | 8'-6" |
| 60" TO 72" | 10'-0" | 9'-0" | 9'-0" |
| 72" TO 84" | 10'-6" | 9'-6" | 9'-6" |
| 84" TO 96" | 11'-0" | 10'-0" | 10'-0" |
| 96" TO 108" | 11'-6" | 10'-6" | 10'-6" |
| 108" TO 120" | 12'-0" | 11'-0" | 11'-0" |

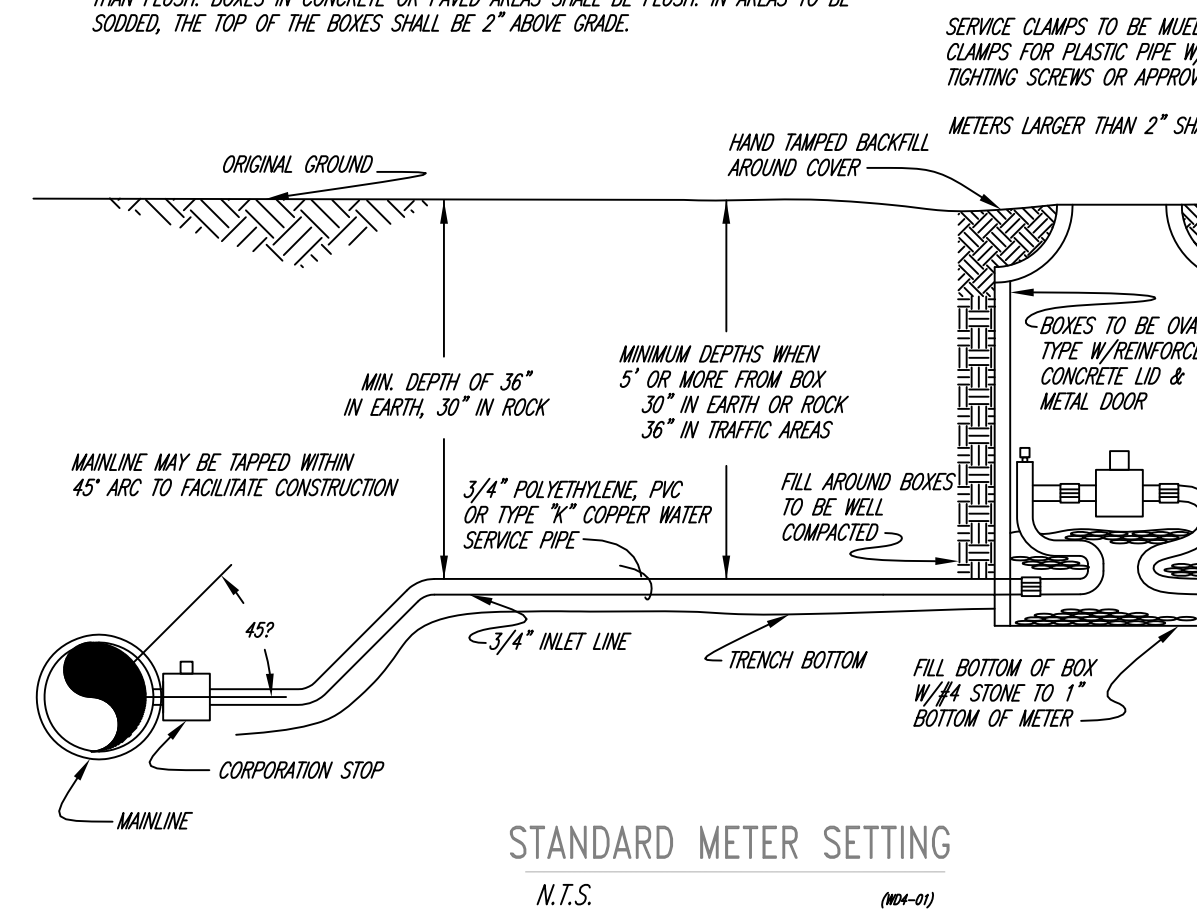

SURFACE RESTORATION

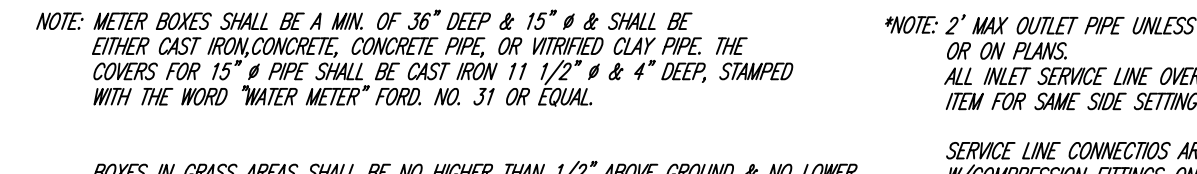
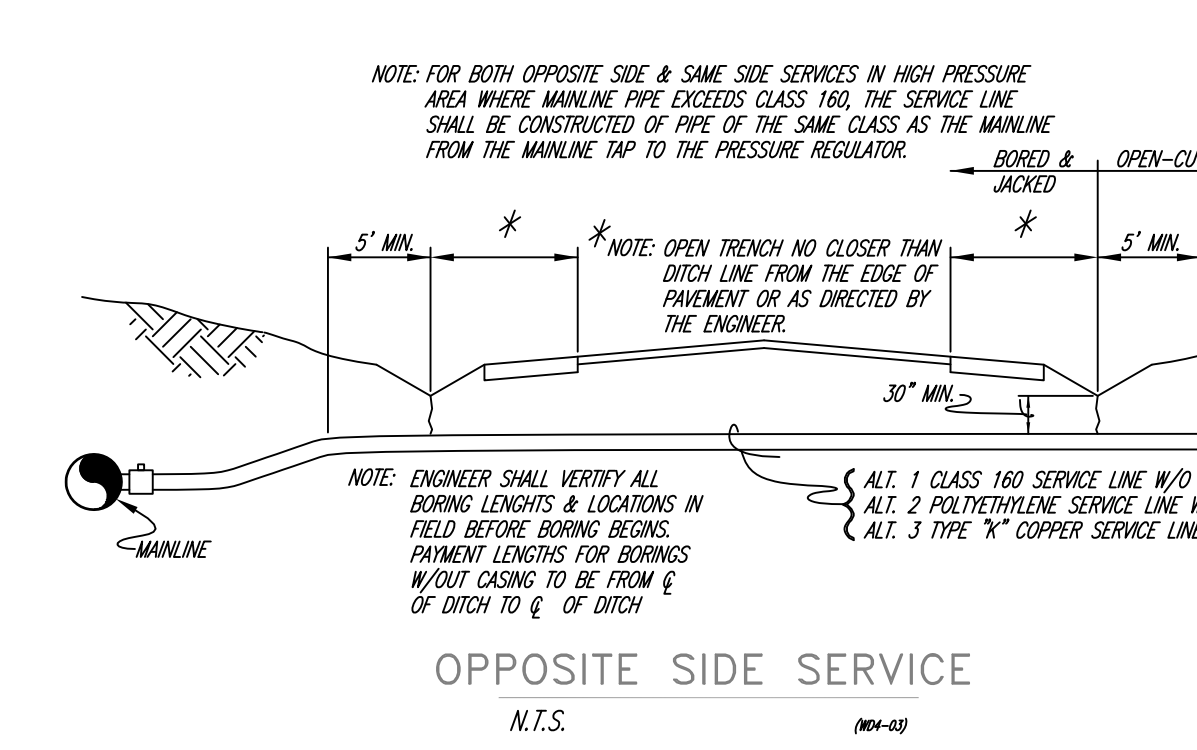
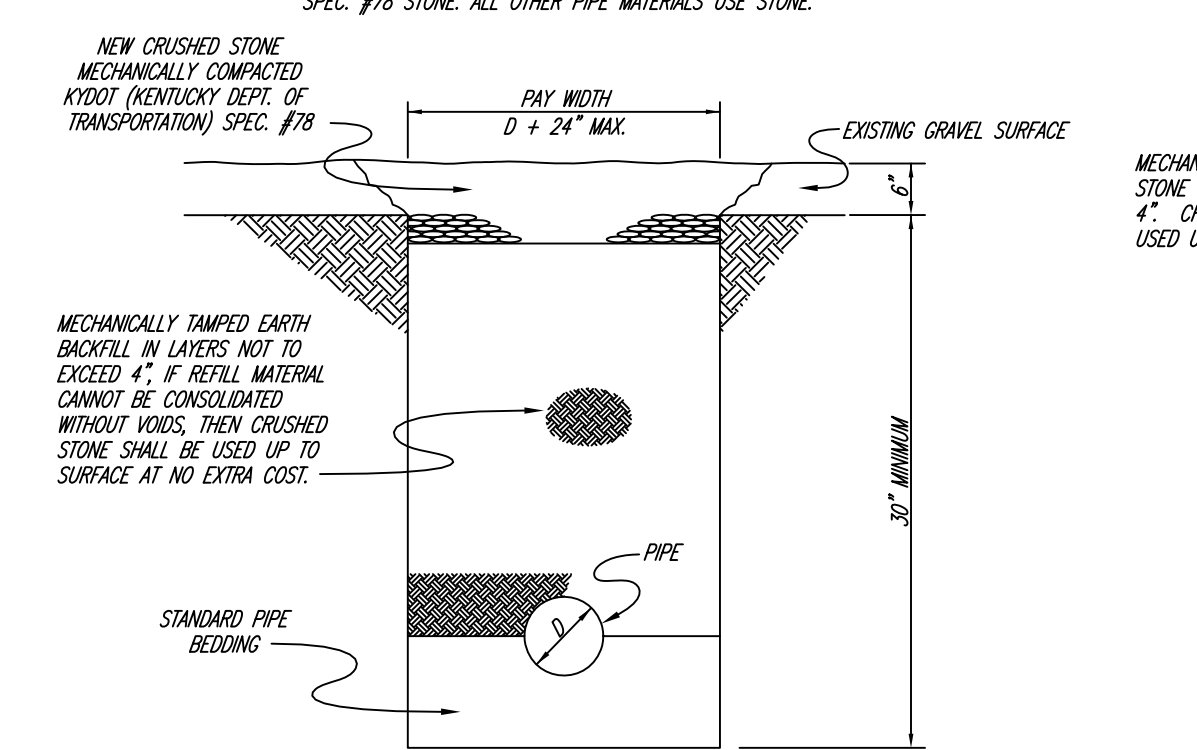
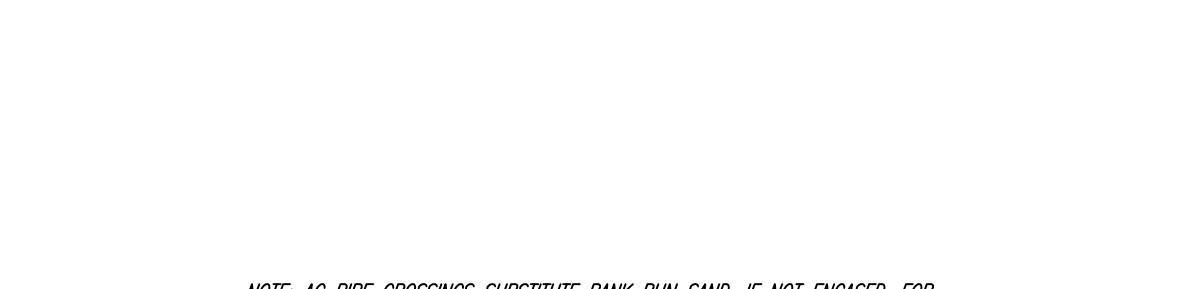
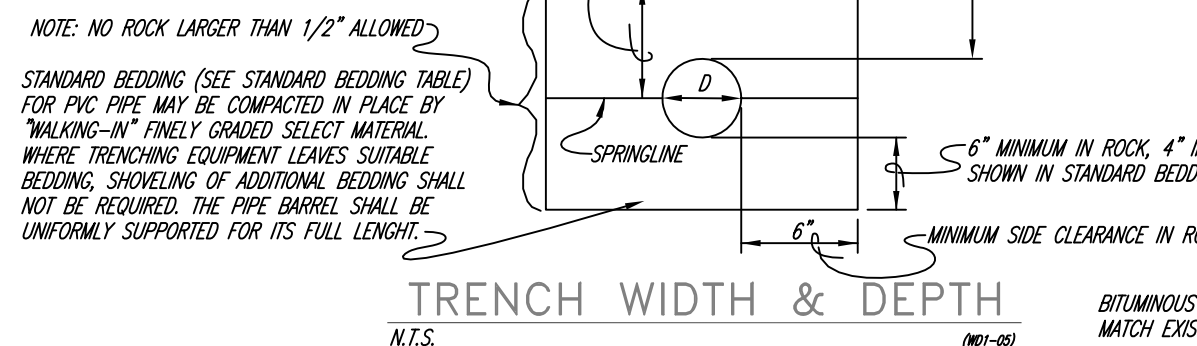
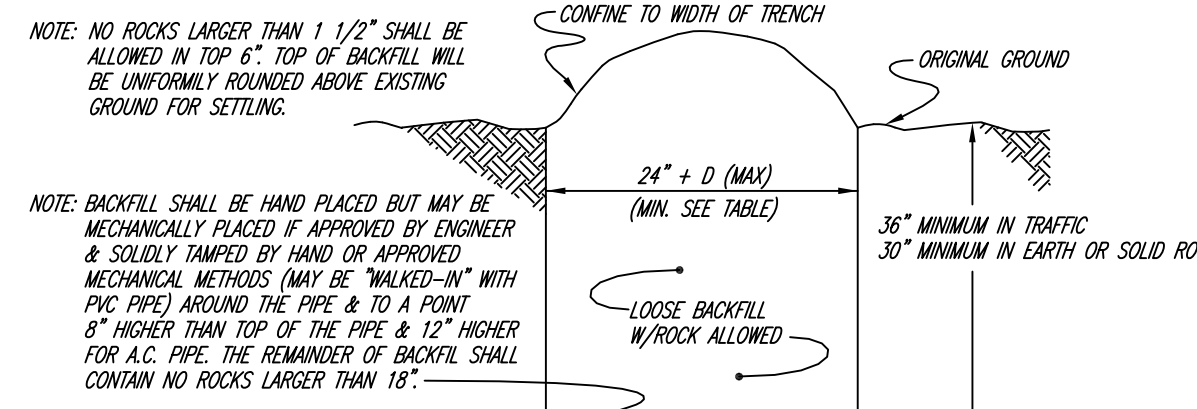
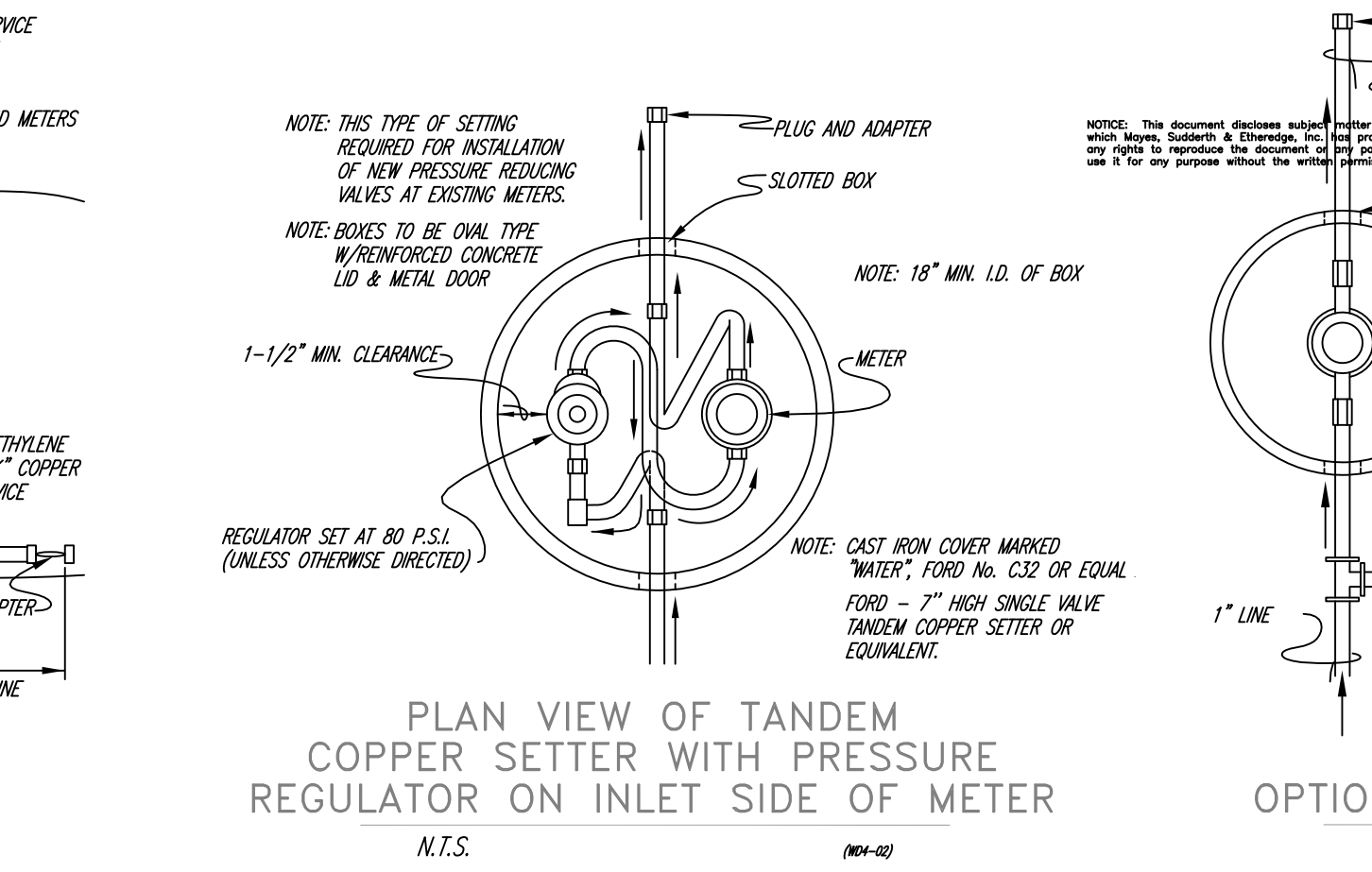
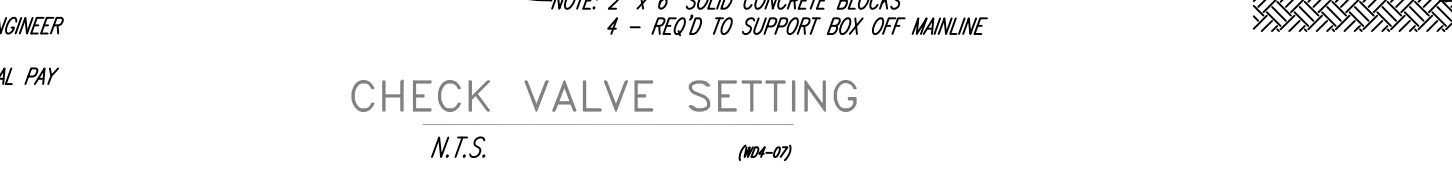
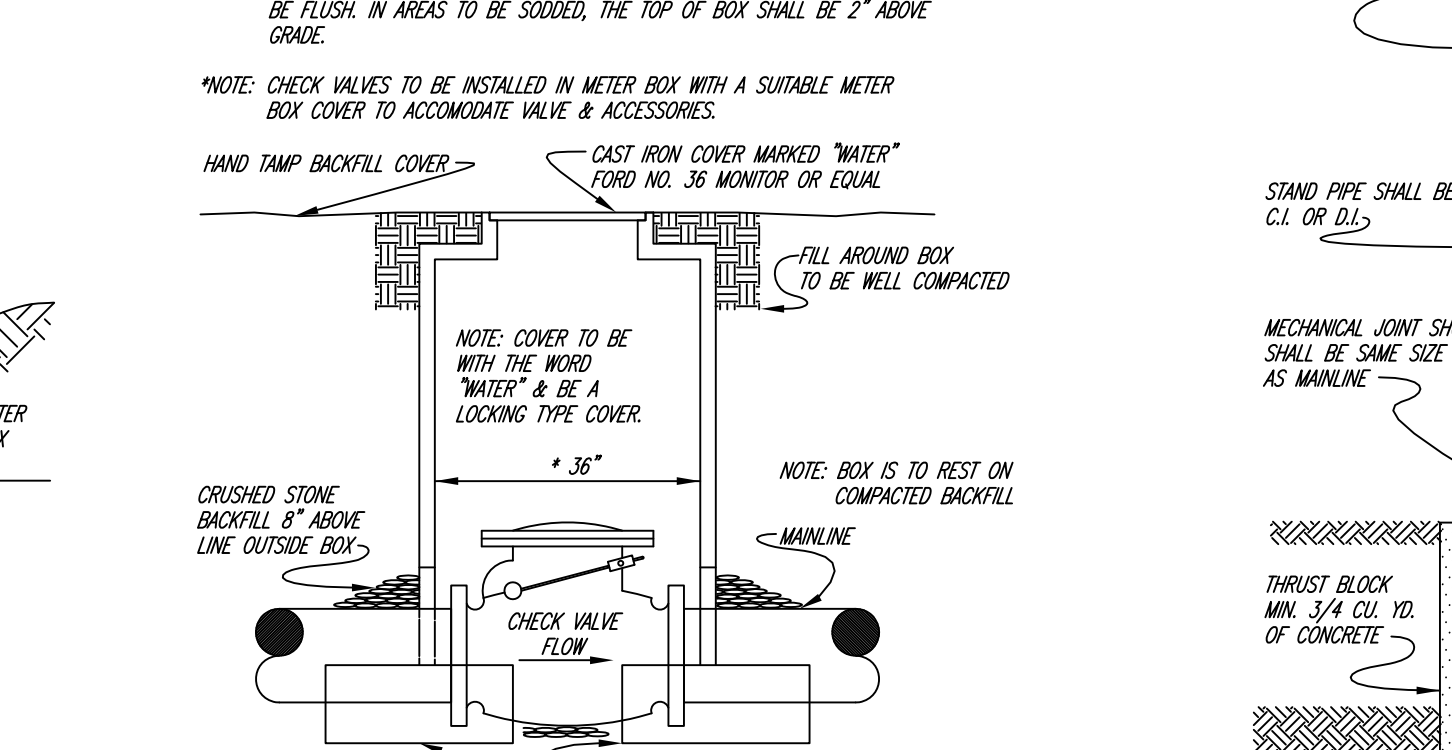
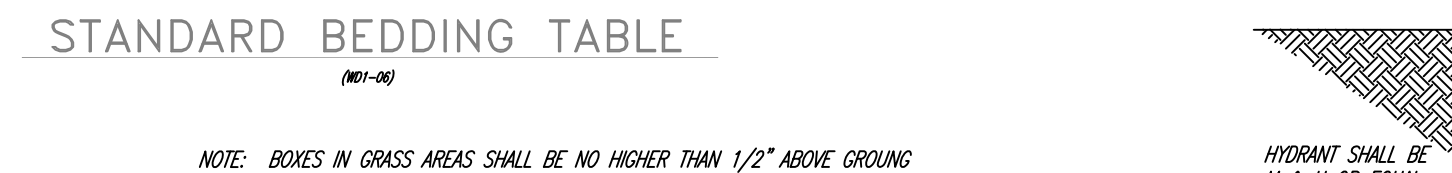
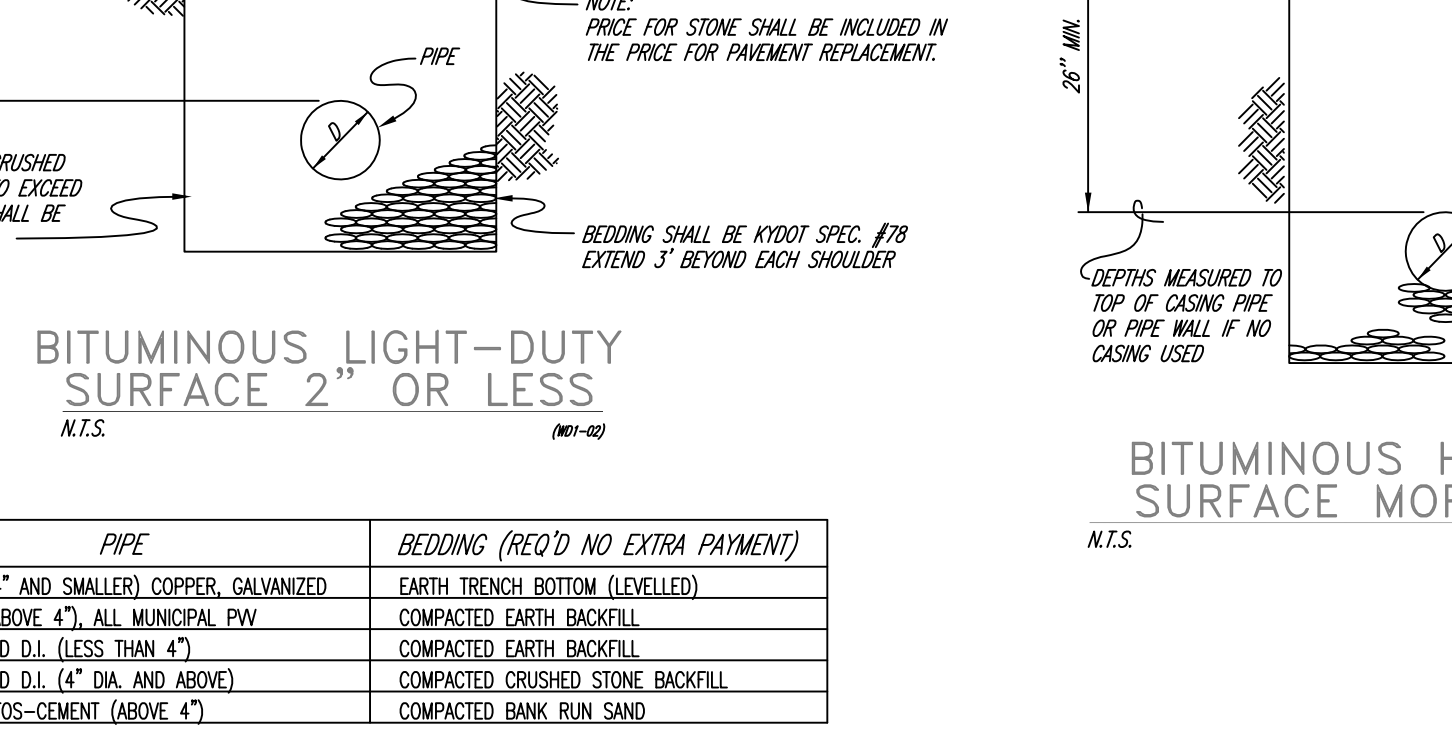
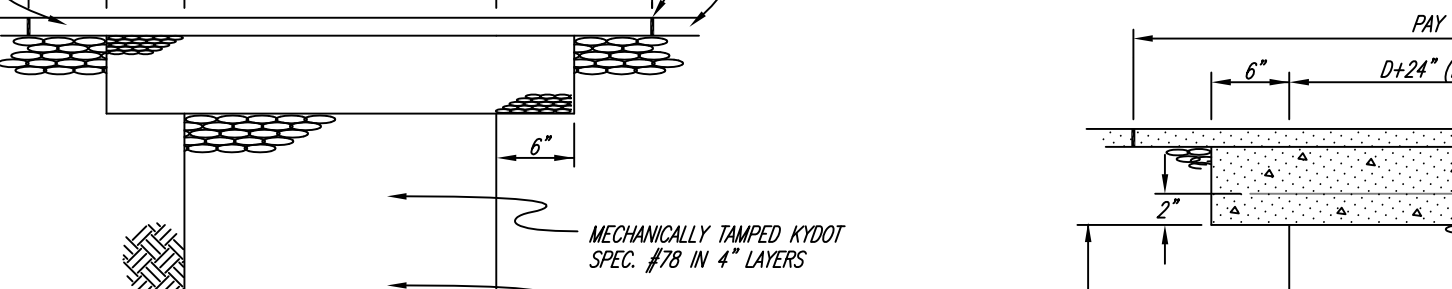
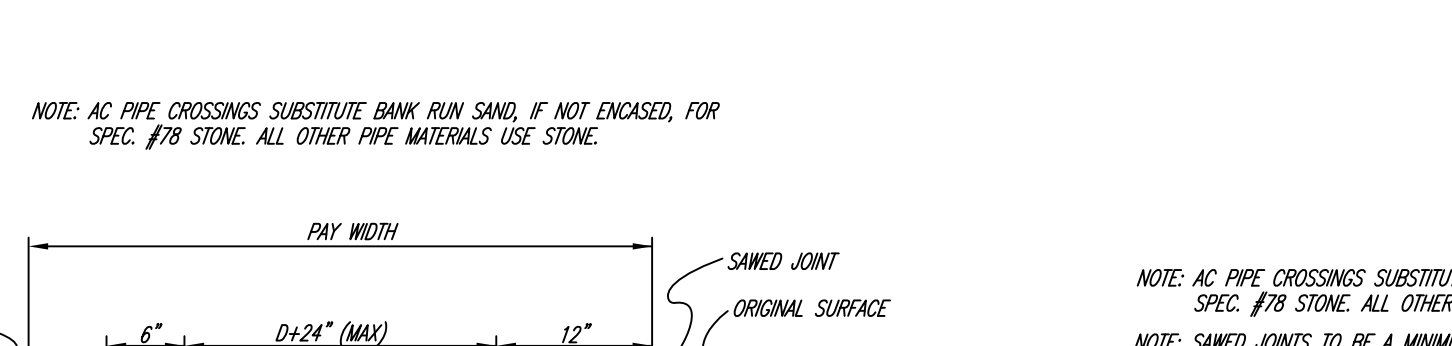
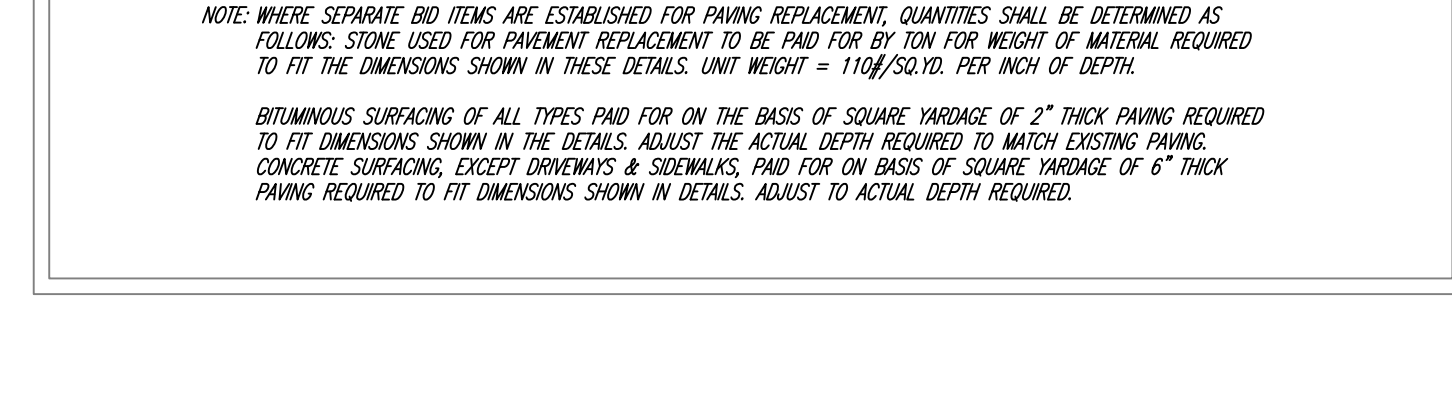

UNDERCUTTING METHOD

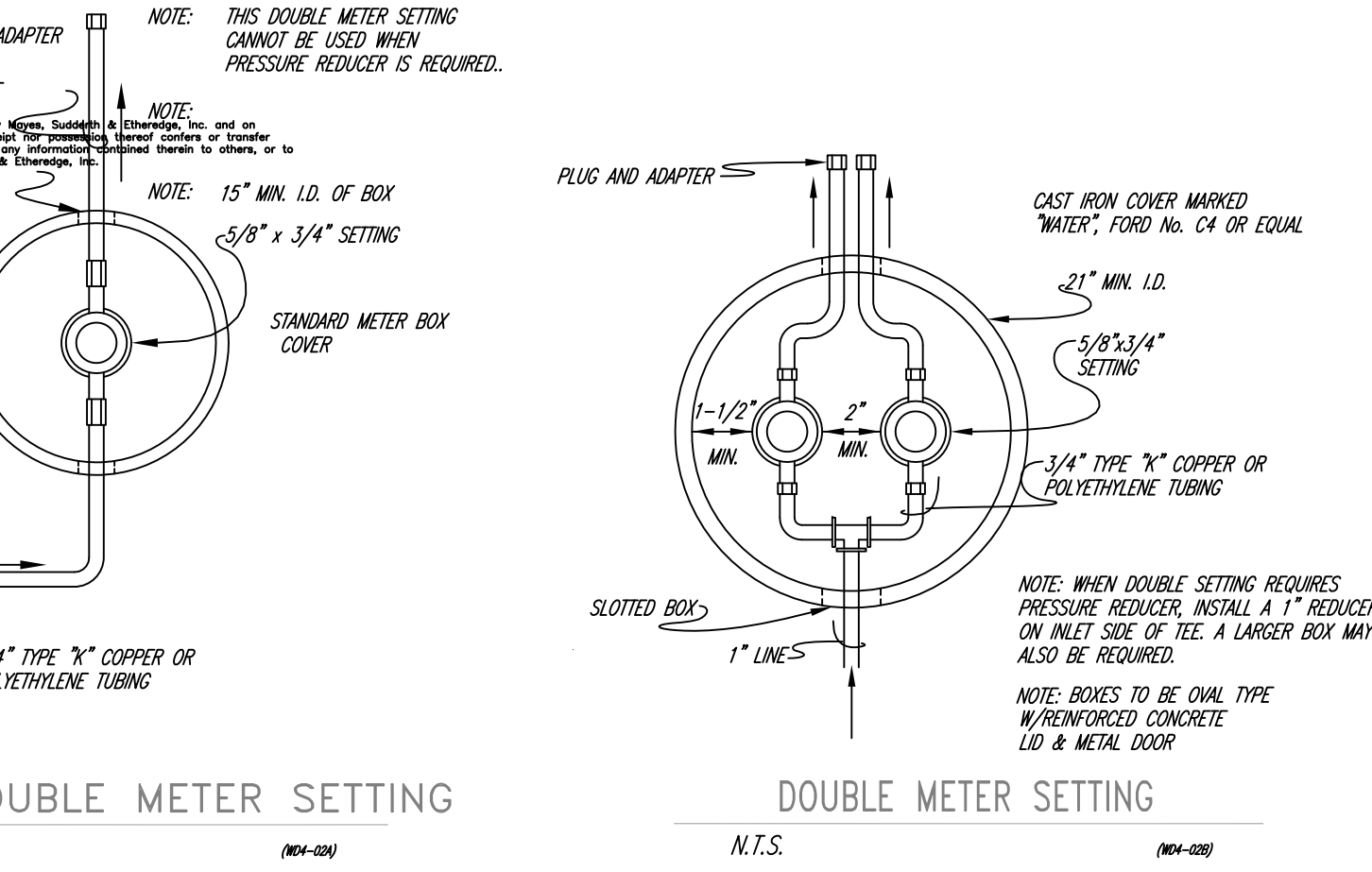
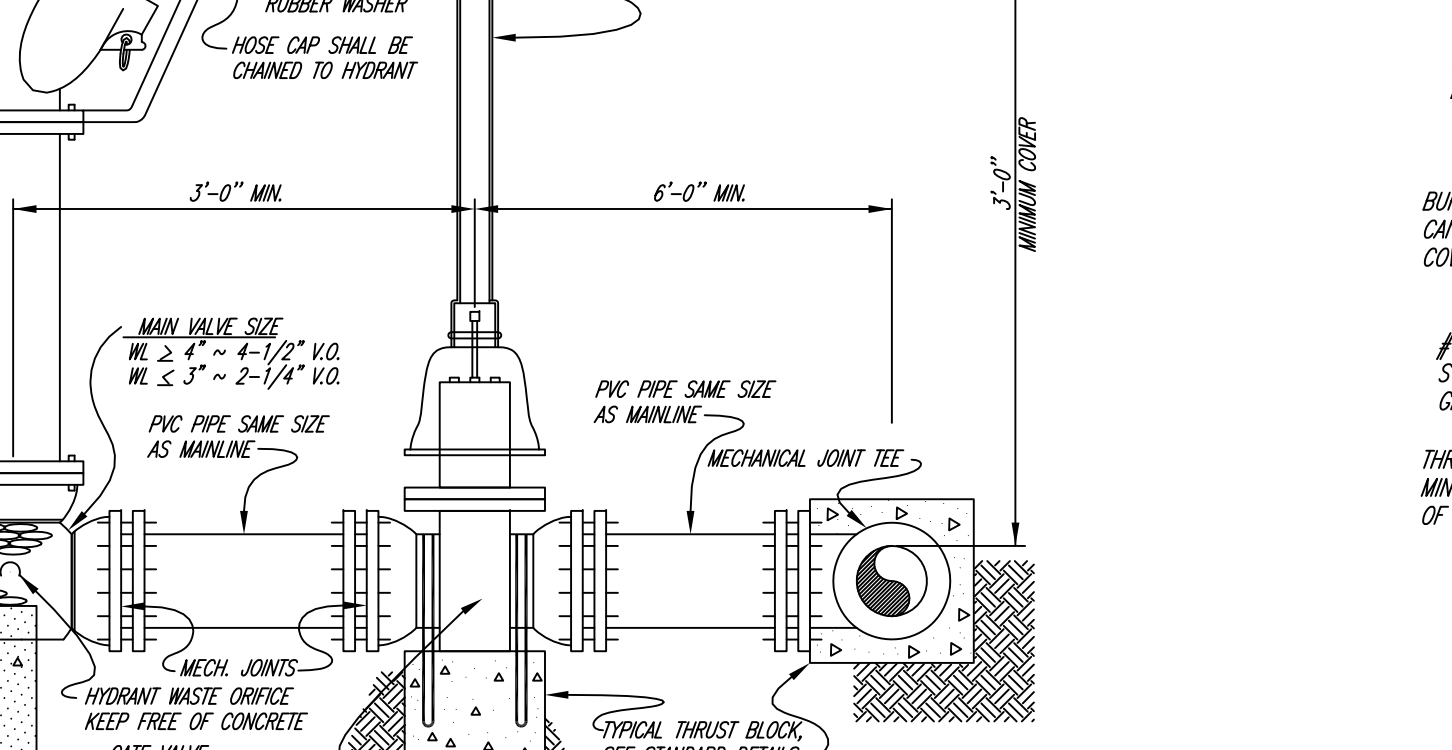
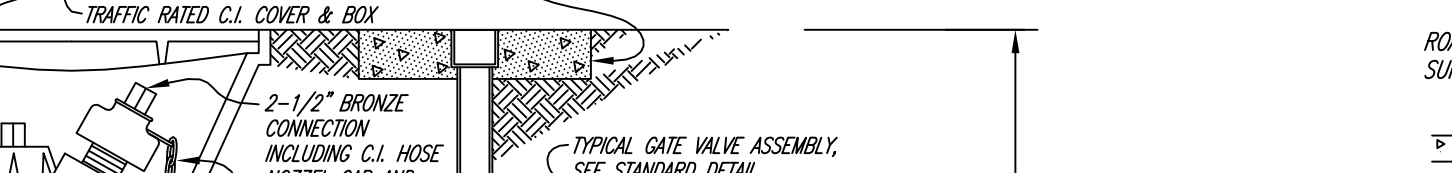
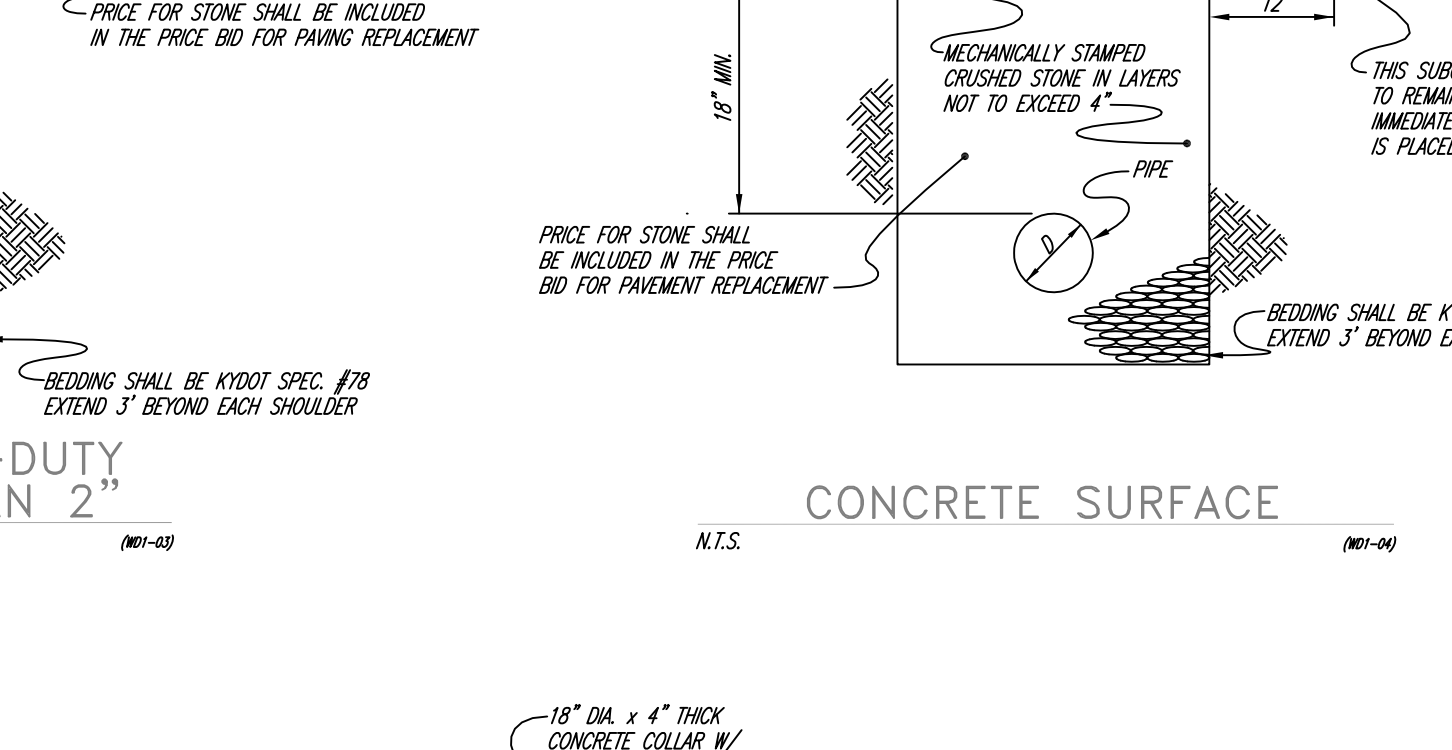
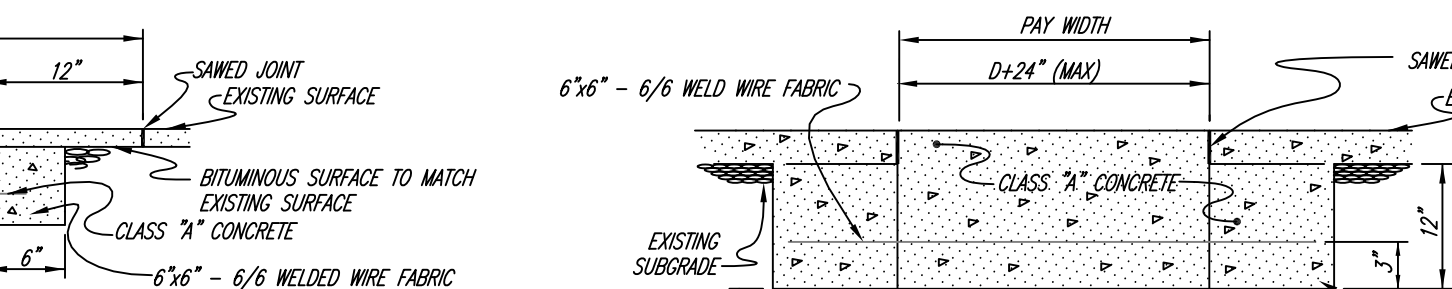
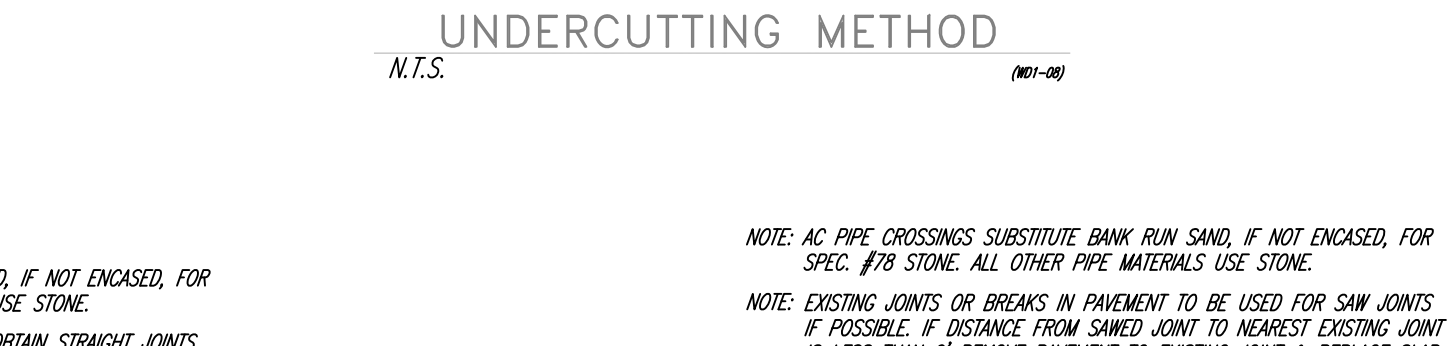
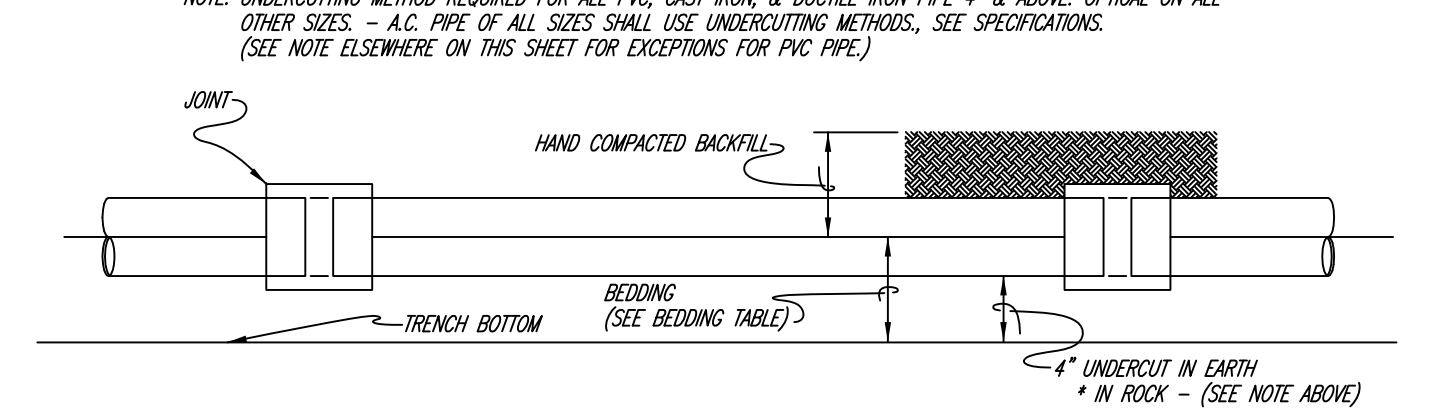

SOLID TRENCH BOTTOM METHOD

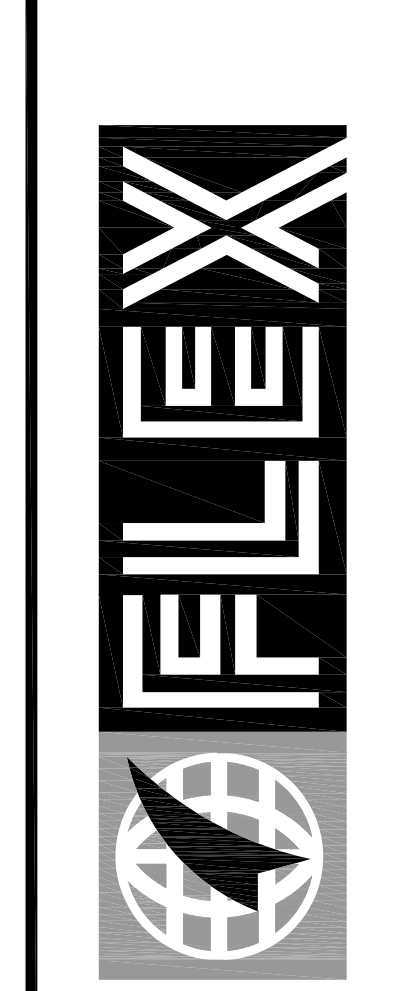
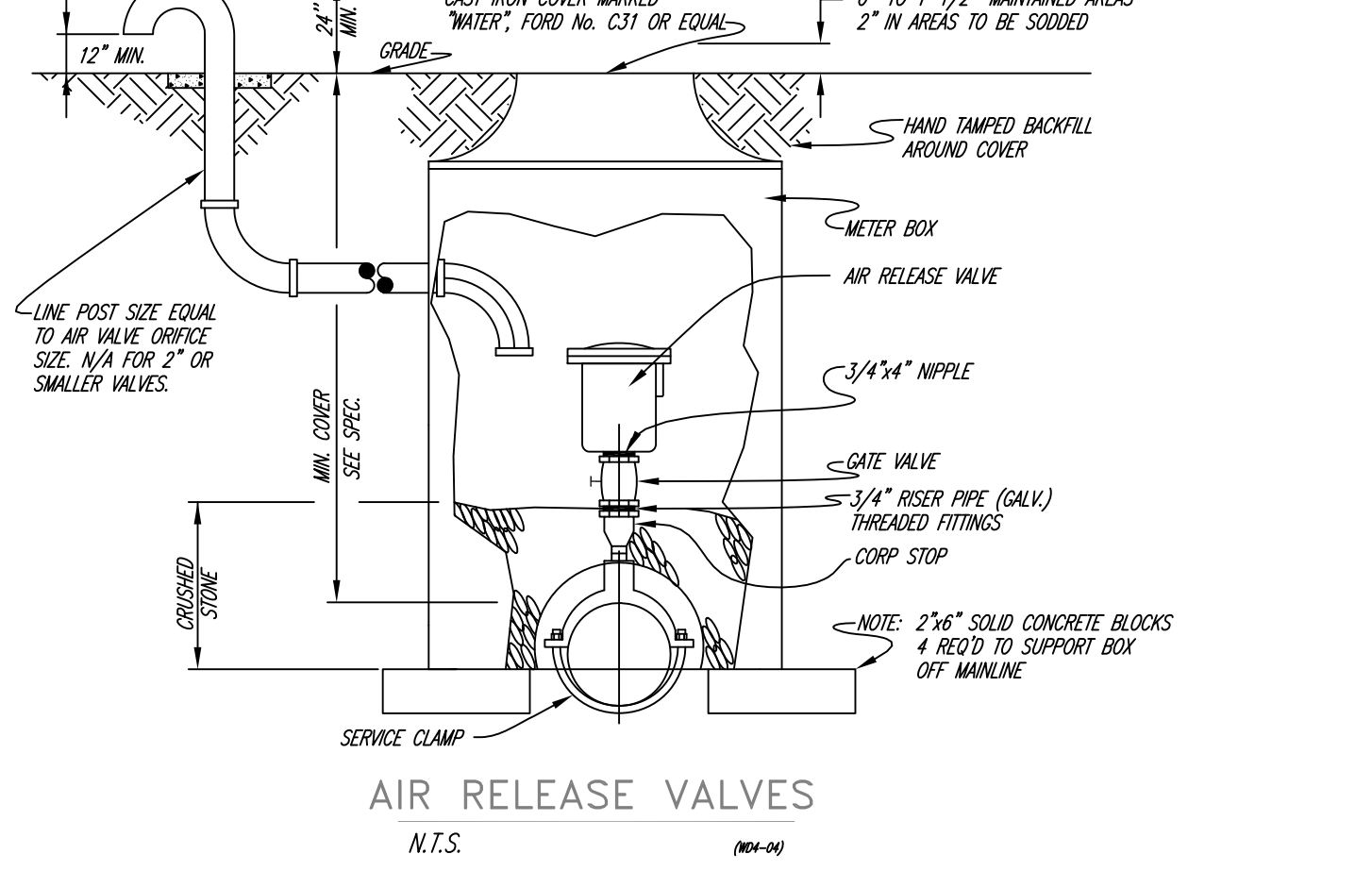
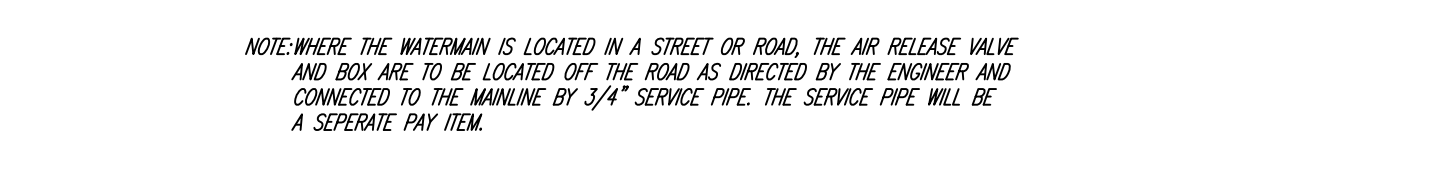
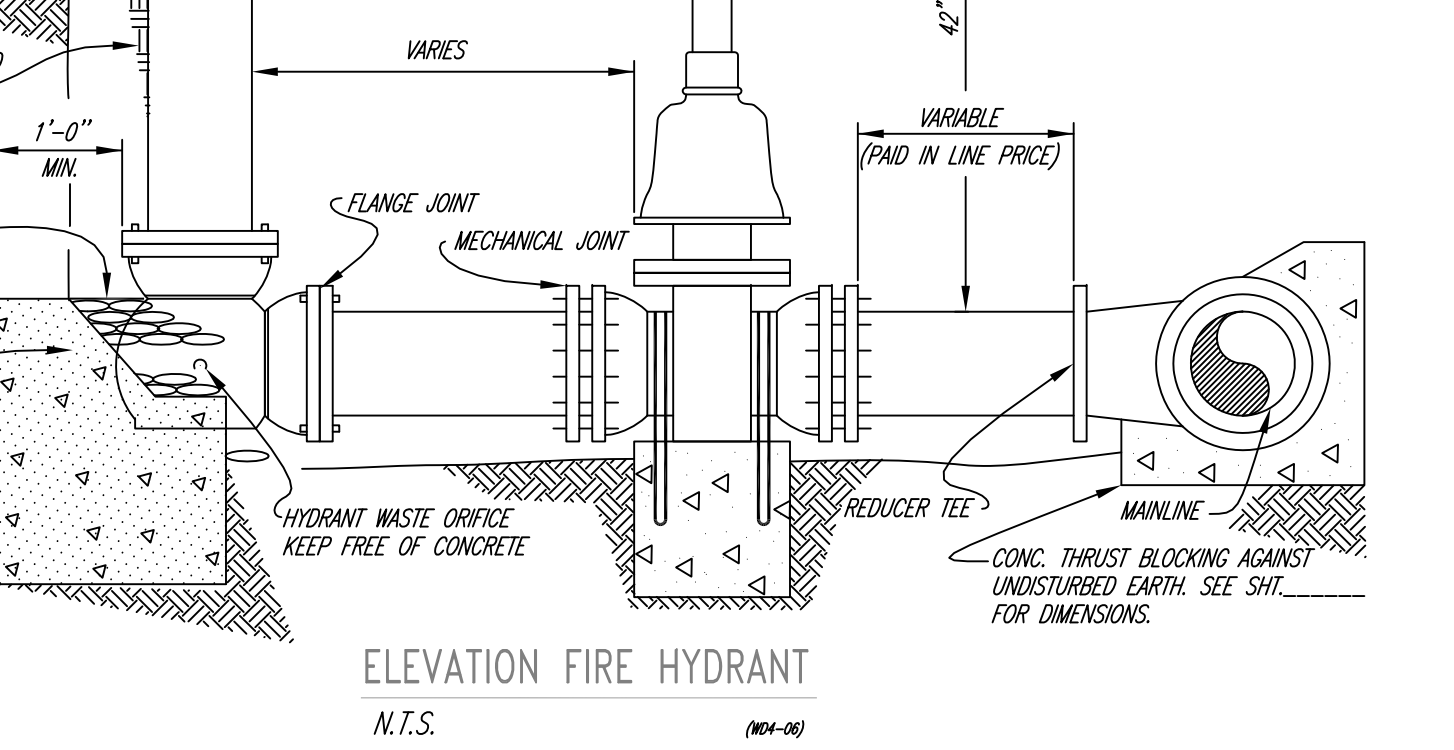
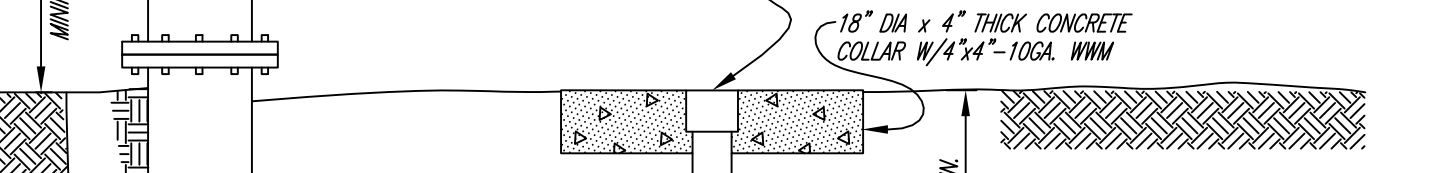
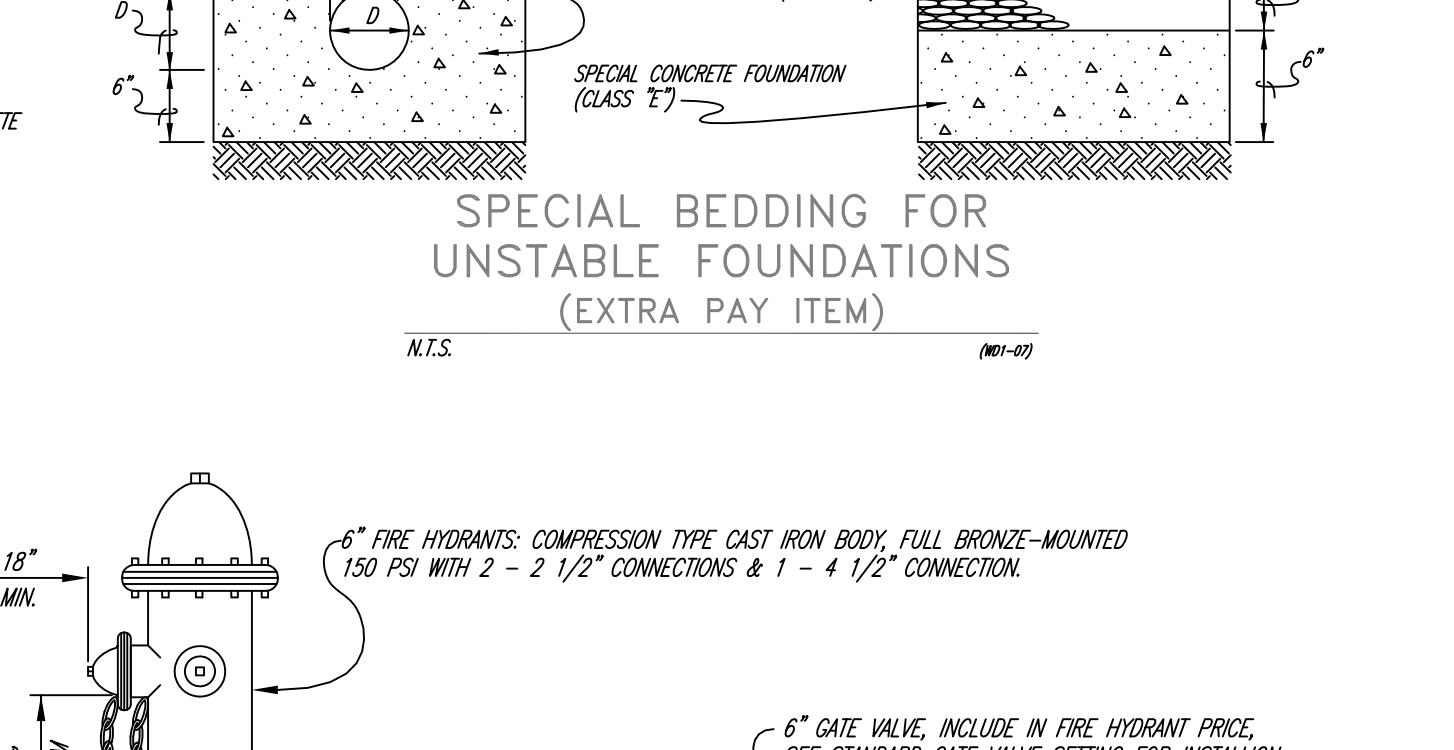
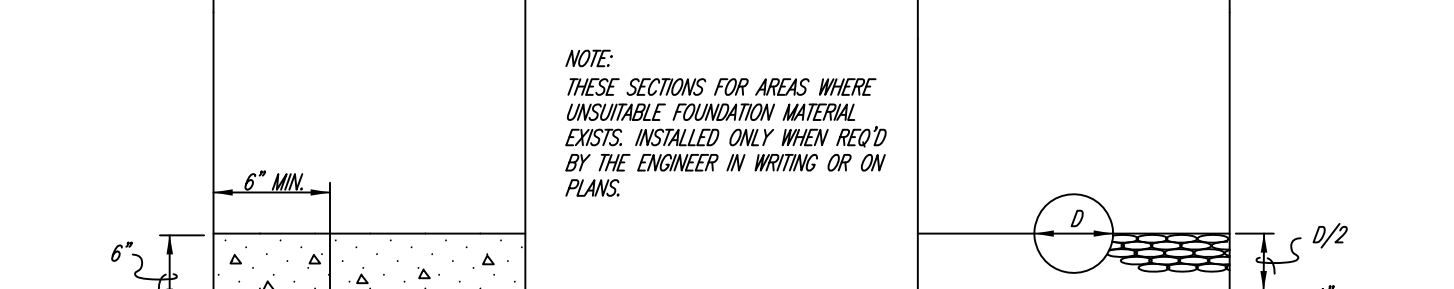
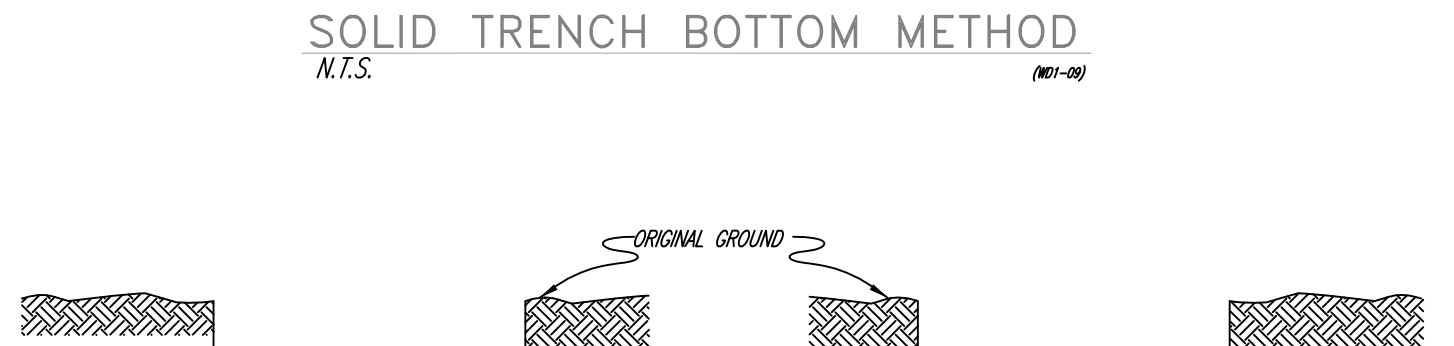
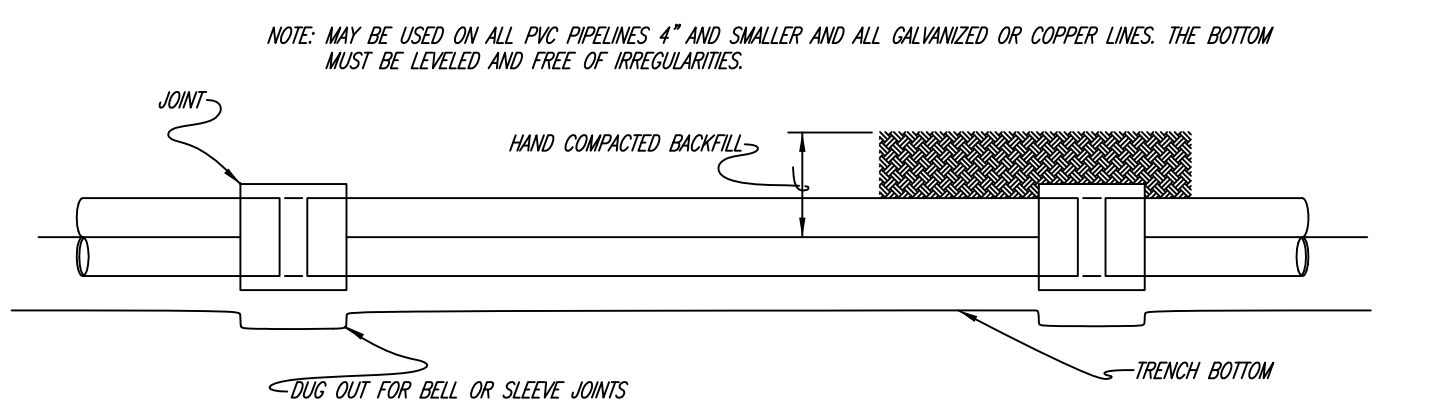

FLEX FILMS (U.S.A.) INC.
 1221 NORTH BLACK BRANCH ROAD
 ELIZABETHTOWN, KENTUCKY 42702

PROJECT L-12 BOPET U.S.A.

| DATE | REVISION | BY |
|------|----------|----|
| | | |
| | | |
| | | |
| | | |

PROJECT NO. 2064-25
 DESIGNED BY G.A.R.
 DRAWN BY J.R.M.
 CHECKED BY G.A.R.
 REVIEWED BY G.A.R.
 DATE - JUNE, 2011
 SCALE - AS SHOWN

nse
 OF KENTUCKY, INC.
 Engineers
 Architects
 Planners
 624 Wallington Way
 Lexington, KY 40503
 Phone: (859)223-5664
 Fax: (859)223-2607
 www.nseinc.com

WATERLINE DETAILS

DRAWING NO.
UFL-L12
C-112.1

JUL 29 X:\2064-25 FLEX FILM - ELIZABETHTOWN T.J. PATTERSON INDUSTRIAL PARK, C-112, C-122.1, C-122.2 SITE WATERLINE PLAN AND DETAILS.